

JB 型可调阻尼弹簧减震器安装说明

JB spring isolator installation guide

安装前，请确认淞江集团弹簧减震器的型号和规格是否正确。

Before installation, make sure the model and the specification are correct.

安装说明

Installation guide

所需工具：公制口径 17mm (M10)、19mm (M12) 开口扳手、爪式千斤顶。

Required tools: 17mm (M10)、19mm (M12) open wrenches and claw jack.

可先放置与弹簧减震器高度相同的临时木块与设备安装处，再安装设备。（如图 1）

Place the wooden panel with the same height as the isolator at the installation before installing. (Fig 1)

先将固定螺栓的上部螺帽取下，再放松下部的螺母使全牙螺栓下降，以方便将弹簧减震器放入安装位置。（如图 2）

Remove the upper nuts from the fixed bolt. Loosen the lower nuts to descend the full-thread bolt to install the isolator. (Fig 2)

根据螺栓固定孔的位置，与安装位置预埋基础螺栓。

Embed foundation bolt according to the location of bolt-loaded holes.

将弹簧减震器放置到与设备的正确安装位置。（如图 3）

Place the isolator on the correct installation location. (Fig 3)

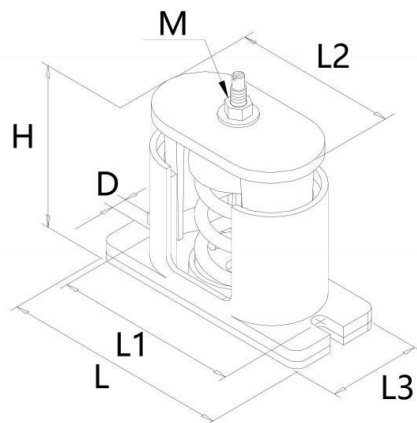

型号/规格	L (mm)	L1 (mm)	L2 (mm)	L3 (mm)	H (mm)	D (mm)	M (mm)
JB-S	155	136	108	75	150	13	12
JB-M	215	195	153	90	175	15	14
JB-L	215	195	153	90	175	15	16

调整下部螺母使全牙螺栓上升至与设备安装处，并将上部螺母与全牙螺栓锁紧。（如图 4）

Adjust lower nuts to raise the full-thread bolt for the installation and slightly lock the upper nuts and full-thread bolt. (Fig 4)

使用开口扳手以顺时针方向调整螺母使弹簧受力下压，调整至临时木台可取出时停止调整。（如图 5）

Apply open wrench in the clockwise direction to press down the spring. Adjustment can be stopped and wooden panel can be removed once you can take out the pressure pad. (Fig 5)

将固定螺栓确保完全锁紧，即完成淞江集团弹簧减震器安装调整。（如图 6）

After the adjustment, lock the isolator with fixed bolt. (Fig 6)

安装后请检查弹簧下压量，如弹簧压到底，则表示荷重不足，没有减震效果。应该更换较大荷重的弹簧减震器型号，并请于本公司业务人员联系。

After the adjustment, check the press amount of the spring. If it appears with insufficient loading, please replace with bigger loading by contacting our staff.

安装时 请注意安全。

Be cautious during the installation.

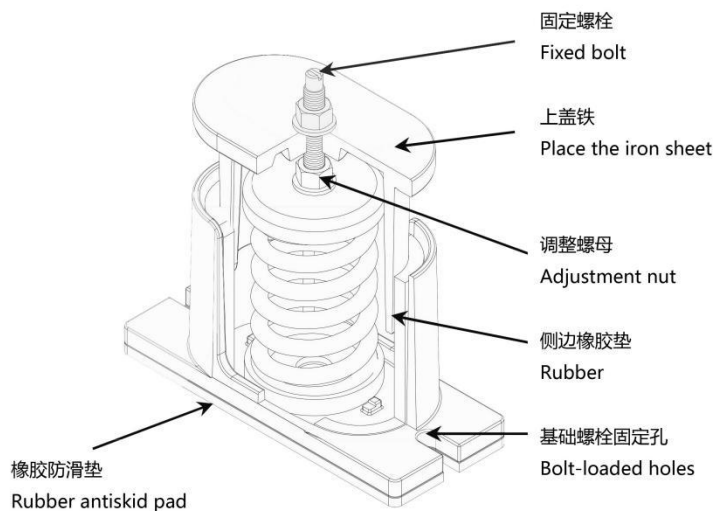

保养须知：每月要观察 CS 固定螺栓是否有松动，保持弹簧减震器安装时弹簧下压挠度是否正常。
 Maintenance checking points: remain M12 fixed bolt locked, balance of the base, installation of the isolator, and the deflection of the spring.



图 1) 安装设备时先放置与弹簧减震器高度相同的木台。

Fig 1) Place the wooden panel with the same height as the isolator at the installation before installing.

图 2) 固定螺栓的上部螺帽先取下来, 再把下部螺帽松掉使螺栓下降, 以便安装。

Fig 2) Remove the upper nuts from the fixed bolt. Loosen the lower nuts to descend the bolt for the installation.

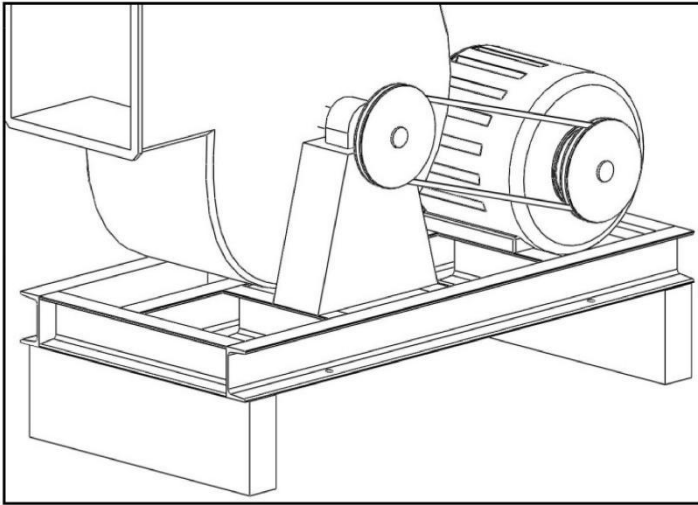

图 3) 将淞江集团弹簧减震器放入设备的安装底部位置。

Fig 3) Place the isolator on the correct installation location.

图 4) 调整下部螺帽使螺栓上升至能与设备连接, 再将固定螺帽锁紧。

Fig 4) Adjust lower nuts to raise the bolt to connect with the equipment and slightly lock the fixed nuts.

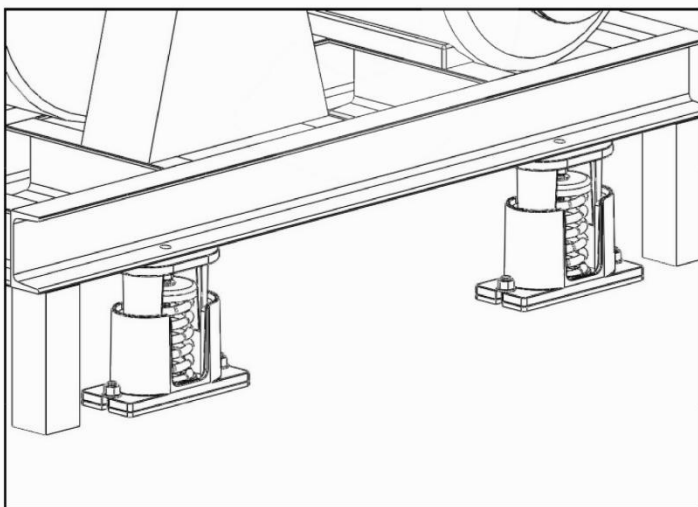
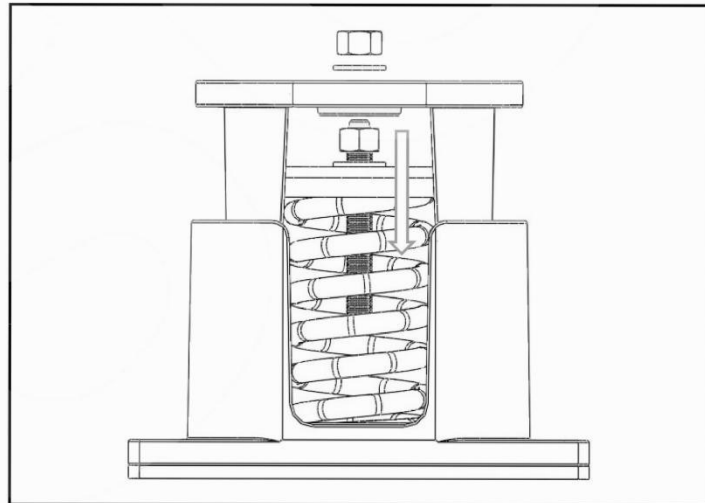

图 5) 用开口扳手以顺时针方向调整螺帽, 调整至临时木台可以取出时即可停止调整。

Fig 5) Apply open wrench in the clockwise direction to adjust the nuts. Adjustment can be stopped once wooden panel is removed.

图 6) 将固定螺栓与设备完全锁紧后, 即完成淞江集团弹簧减震器安装调整。

Fig 6) After the adjustment, lock the isolator with fixed bolt.

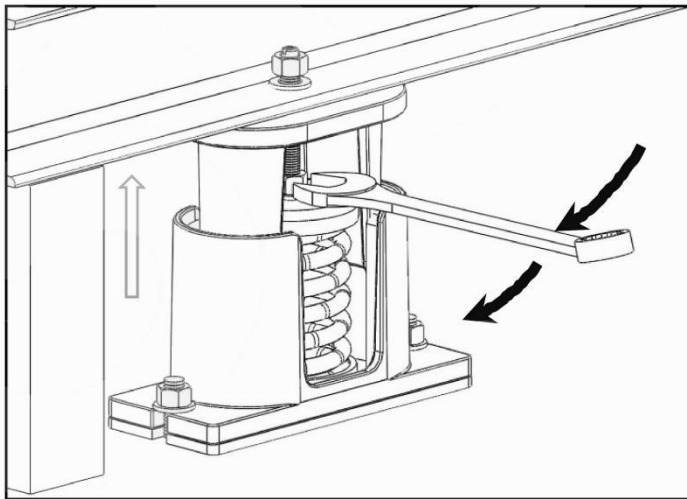
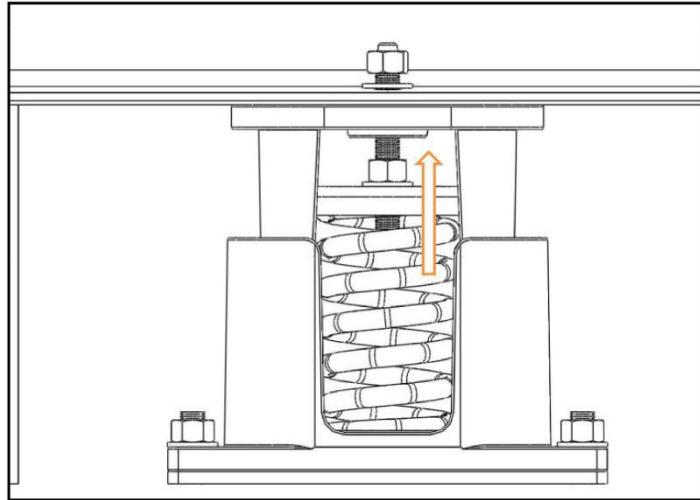